

Seltene Erden:

Ihre Bedeutung als Verstärkermidien für den
Bau von Hochleistungs-Festkörperlasern

Rare Earth Elements:

Gain Media for High Power Solid State Lasers

Materials Valley e.V.

Workshop: Seltene Erden – Ihre Bedeutung für die industrialisierte Welt

Dr. Andreas Langner

Heraeus Quarzglas GmbH & Co. KG

Hanau, 20.01.2011

Outline

- **Historical overview: 50 years of laser development**
- **Elements, we are talking about**
- **Competing high power laser systems**
- **Production techniques for RE doped gain media**
- **Laser market and consequences of China's export control**

Historical overview:
over 50 years of LASER

Invention „LASER“

- **LASER: „Light Amplification by Stimulated Emission of Radiation“**
- 1916: Albert Einstein predicted the stimulated emission theoretically
- 1928: Rudolf Ladenburg proved the stimulated emission experimentally
- 1954: Charles Townes developed the first MASER
- 1960: Theodore Maiman developed the first LASER

[Nature 187, 493 - 494 (1960)]

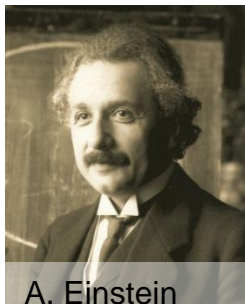

A. Einstein

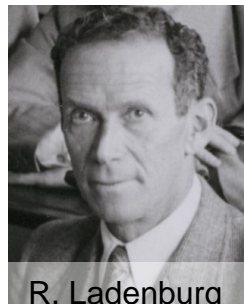

R. Ladenburg



C. Townes



T. Maiman

Principle of a Laser

- Mechanisms for optical transitions:
Absorption, spontaneous emission and stimulated emission
- Indispensable condition for light amplification: **Population inversion**
- Population inversion not achievable in a two-level system due to the same probability for absorption and stimulated emission \Rightarrow **at least three-level system** required
- Driving force for the population inversion: **Pumping (optical, electronical, ...)**
- Driving force for the amplification of stimulated emission: **Resonance** (by mirrors)

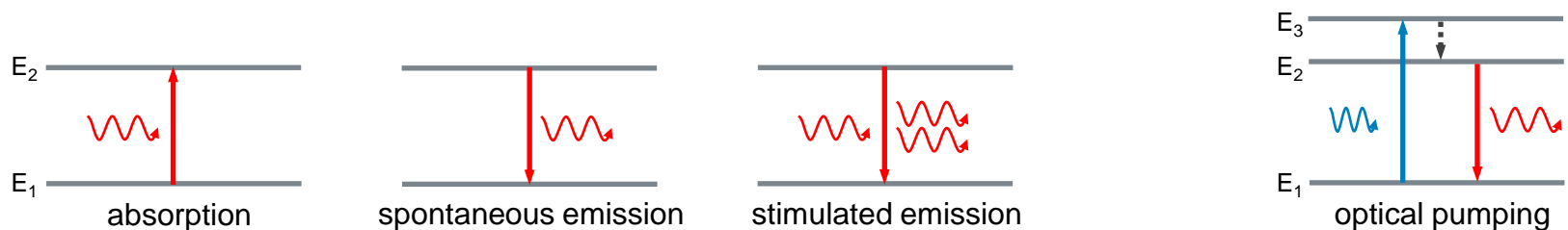

The first LASER developed by T. Maiman

- **Ruby LASER**
- Solid state LASER
- Chromium doped aluminum oxide rod
- Chromium flash lamp pumped
- Laser emission @ 694,3 nm



Historical review of the LASER development

1960

1970

1980

1990

2000

2010

**1960**

T. Maiman:
first solid state Laser:
Ruby Laser

Historical review of the LASER development

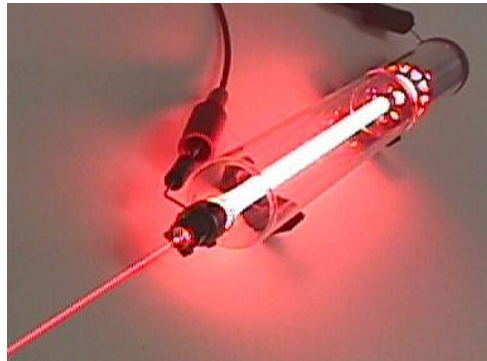

1960
 A. Javan, W. Bennett,
 D. Herriott
 first gas Laser:
He-Ne-Laser



Ruby LASER

Historical review of the LASER development



He-Ne



Ruby



1962
 R. Hall, M. Nathan, T. Quist:
 of the first **diode laser**:
 Zn- and Te-doped GaAs

Historical review of the LASER development



He-Ne

1964

C. Patel: first **CO₂ gas laser**

J. Geusic: first **Nd:YAG laser**

1960

1970

1980

1990

2000

2010



Diode



Ruby

Historical review of the LASER development



He-Ne

CO₂
Nd:YAG

1960

1970

1980

1990

2000

2010



Diode



Ruby

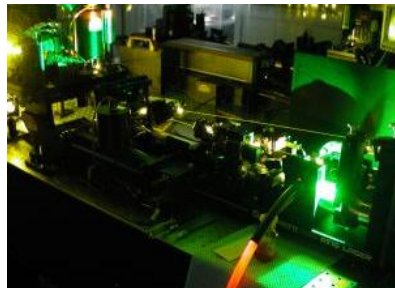

1966
P. Sorokin, J. Lankard:
first dye laser

Historical review of the LASER development



He-Ne

**CO₂
Nd:YAG**



Diode

1966
Laser marking and engraving
of metals and other materials

1967
Laser cutting of metal sheets



Ruby

Dye

Historical review of the LASER development



He-Ne

**CO₂
Nd:YAG**

1960

1970

1980

1990

2000

2010



Diode

1971
Drilling of micro
and macro holes

**Marking and
engraving**



Ruby

Dye

Historical review of the LASER development



He-Ne

CO₂
Nd:YAG



1978

Deutsche Bundespost installs first fiber optical network in Berlin. The installed cable successfully uses silica fibers made with Heraeus' preforms.



Diode

Hole drilling

Marking and engraving



Ruby

Dye

Historical review of the LASER development



He-Ne

CO₂
Nd:YAG

First German
telecom cable



1960

1970

1980

1990

2000

2010



Diode

Hole drilling

Marking and
engraving



Ruby

Dye

1980th

- Er-doped fiber amplifiers for T-com (EDFA)
- Ti-Sa laser for ps and fs pulses
- Diode pumped solid state laser for high power applications (DPSSL)
- Diode lasers for consumer electronics (e.g. CD player)
- 3D rapid prototyping

Historical review of the LASER development



He-Ne

CO₂
Nd:YAG

First German
telecom cable



1990th

- New pump designs for high power lasers
 - Disk laser
 - Fiber laser
- Medical applications
 - Refractive eye surgery (LASIK)
 - Laser lithotripsy
 - Prostate tissue removal (TURP)



Diode



Ruby

Hole drilling

Marking and
engraving

Dye

- EDFA for T-com
- Ti-Sa
- DPSSL
- Diode lasers
e.g. for CD player
- Rapid prototyping

Historical review of the LASER development



He-Ne

CO₂
Nd:YAG

First German
telecom cable



- Disk laser
- Fiber laser
- Medical applications

1960

1970

1980

1990

2000

2010



Diode



Ruby

Hole drilling

Marking and
engraving

Dye

- EDFA for T-com
- Ti-Sa
- DPSSL
- Diode lasers
e.g. for CD player
- Rapid prototyping

Since 2000

- Output power of fiber lasers drastically increased (above 50 kW; competition to CO₂)
- Attosecond X-Ray laser
- Petawatt lasers:
 - Heavy ion experiments (PHLIX)
 - Nuclear fusion (NIF)

Elements, we are talking about

	I	II											III	IV	V	VI	VII	VIII	
1	1 H																		2 He
2	3 Li	4 Be											5 B	6 C	7 N	8 O	9 F	10 Ne	
3	11 Na	12 Mg											13 Al	14 Si	15 P	16 S	17 Cl	18 Ar	
4	19 K	20 Ca	21 Sc	22 Ti	23 V	24 Cr	25 Mn	26 Fe	27 Co	28 Ni	29 Cu	30 Zn	31 Ga	32 Ge	33 As	34 Se	35 Br	36 Kr	
5	37 Rb	38 Sr	39 Y	40 Zr	41 Nb	42 Mo	43 Tc	44 Ru	45 Rh	46 Pd	47 Ag	48 Cd	49 In	50 Sn	51 Sb	52 Te	53 I	54 Xe	
6	55 Cs	56 Ba	57 La	72 Hf	73 Ta	74 W	75 Re	76 Os	77 Ir	78 Pt	79 Au	80 Hg	81 Tl	82 Pb	83 Bi	84 Po	85 At	86 Rn	
7	87 Fr	88 Ra	89 Ac	104 Rf	105 Db	106 Sg	107 Bh	108 Hs	109 Mt	110 Ds	111 Rg	112 Uub	113 Uut	114 Uuq	115 Uup	116 Uuh	117 Uus	118 Uuo	
8	119 Uun																		
	* Lanthanides		57 La	58 Ce	59 Pr	60 Nd	61 Pm	62 Sm	63 Eu	64 Gd	65 Tb	66 Dy	67 Ho	68 Er	69 Tm	70 Yb	71 Lu		
	** Actinides		89 Ac	90 Th	91 Pa	92 U	93 Np	94 Pu	95 Am	96 Cm	97 Bk	98 Cf	99 Es	100 Fm	101 Md	102 No	103 Lr		

RE elements mainly utilized for laser

Element	Utilization
Y	Host crystal for lasers (e.g. $Y_3Al_2O_{12}$ = YAG)
Ce, La	Co-dopant to tailor material properties
Nd	Active ion for lasers (e.g., Nd:YAG; 1.06 μm emission)
Ho	Active ion for lasers (e.g., Ho:YAG; 2.08 μm emission)
Er	Active ion for lasers (e.g., Er:YAG; 2.08 μm emission)
Tm	Active ion for lasers (e.g., Tm:YAG, 2.01 μm emission)
Yb	Active ion for lasers (e.g., Yb:glass, 1.08 μm emission)

Sc, Gd, Lu, Pr are also used for some special laser applications as part of the host lattice or as active ion.

Function of rare earth elements as gain media

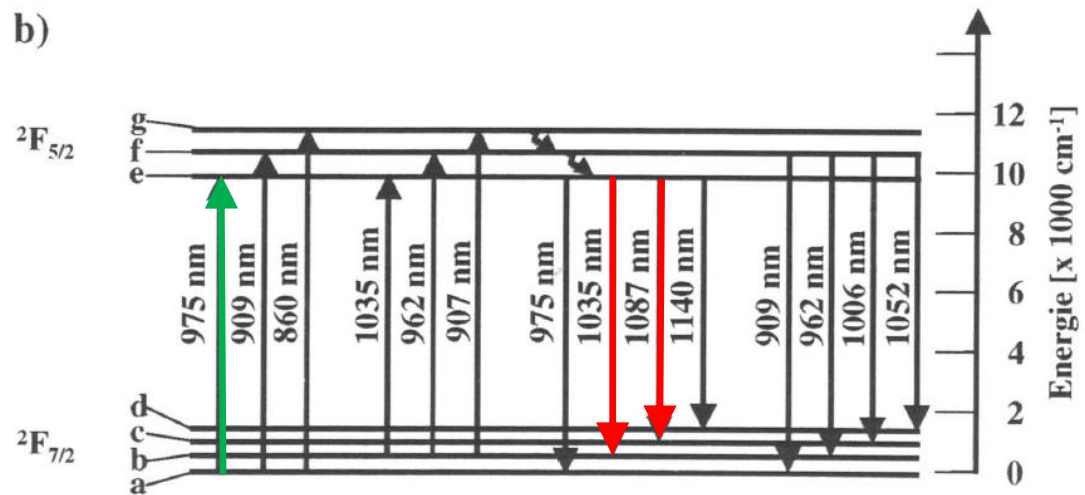
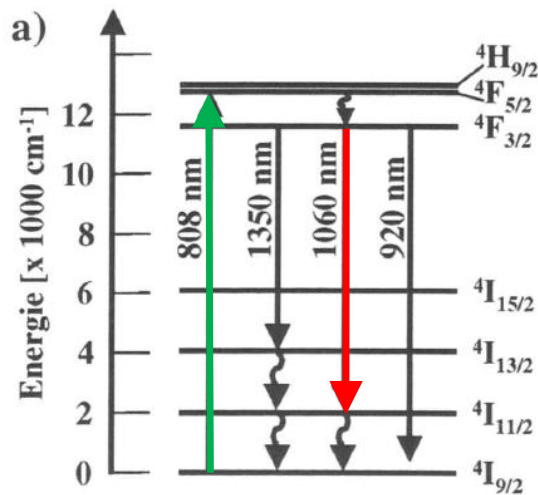

[Lit: Dissertation A. Liem, Uni Jena 2003]

Nd system

- Four level system
- Low influence of the crystal lattice (4f shell shielded by optically passive outer shells)

Yb system

- 975 nm excitation: three level system
- Low influence of the crystal lattice
- Lower heat generation compared to Nd

Competing High Power Laser Systems

Competing high power laser systems

CO₂-Laser

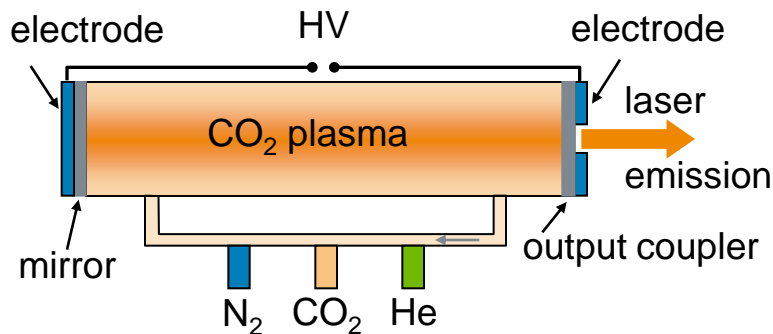

- Gas discharge laser
- Filling gas: CO₂, N₂, He
- Wavelength: 10.6 μm
- Efficiency: 5 ... 10 %
- Excellent performance for thick metal sheet cutting

Direct Diode Laser

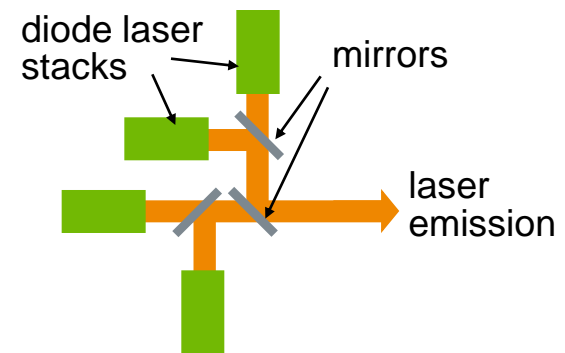

- Combination of several diode laser stacks
- Wavelength: 800 – 1000 nm
- Most efficient (~ 30 %)
- Good cost-performance ratio
- Poor beam quality

Competing high power laser systems

Nd:YAG Laser

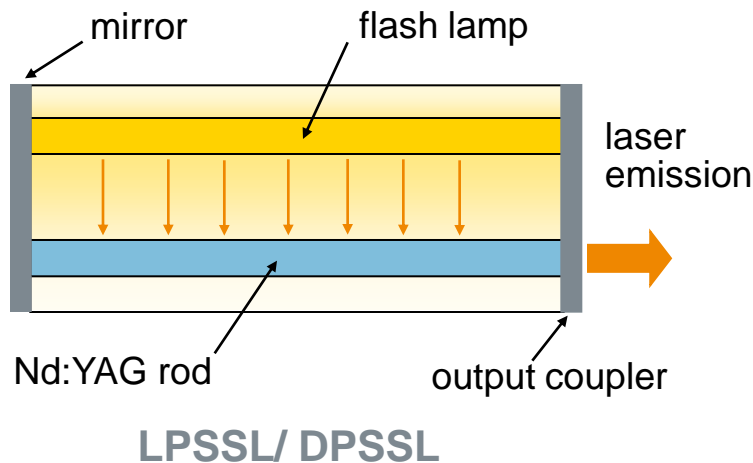

- Diode/ lamp pumped solid state laser (DPSSL/ LPSSL)
- Wall plug efficiency:
 LPSSL: 1 ... 2 %
 DPSSL: 10 ... 20 %
 Slab laser: ~ 15 %
- Active medium: Nd:YAG, Yb:YAG, Nd:YVO₄, Ruby, ...
- Wavelength: 1064 nm (Nd:YAG)
- Thermal lensing

Competing high power laser systems

Thin-Disk Laser

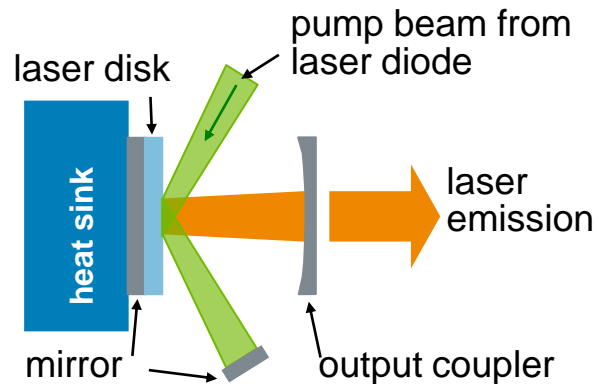

Disk Laser

- Diode pumped solid state laser
- Wall plug efficiency: 15 ... 25 %
- Active medium: Yb:YAG, Nd:YAG
- Disk thickness typ. ~ 100 μm
- Wavelength: 1030 nm (Yb:YAG)
- Reduced thermal lensing by efficient cooling

Competing high power laser systems

Fiber Laser

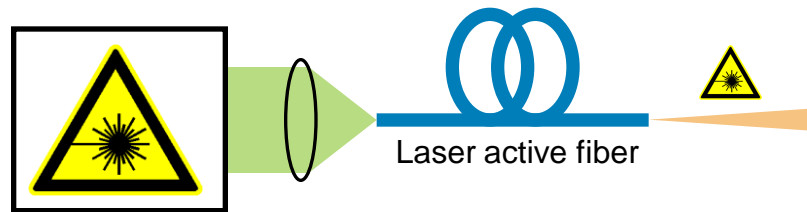

Pump light source (diode laser)

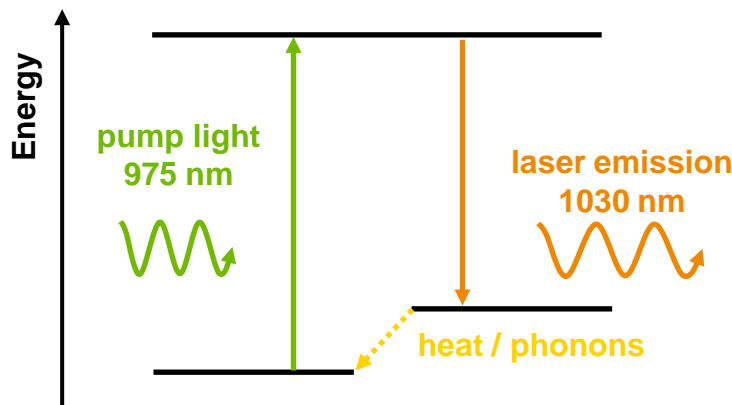

Energy diagram of an Yb:glass fiber

- Brightness converter / beam shaper:
- Excellent beam quality independent of output power ($M^2 \sim 1$)
- Wall plug efficiency: 25 ... 30 %
- Active medium: Yb:glass, Nd:glass, Er:glass, ...
- Low heat generation for Yb:glass
- Efficient fiber cooling
- No free space optics \Rightarrow no misalignment
- Wavelength \sim 1030 ... 1080 nm

End-pumped fiber laser set-up

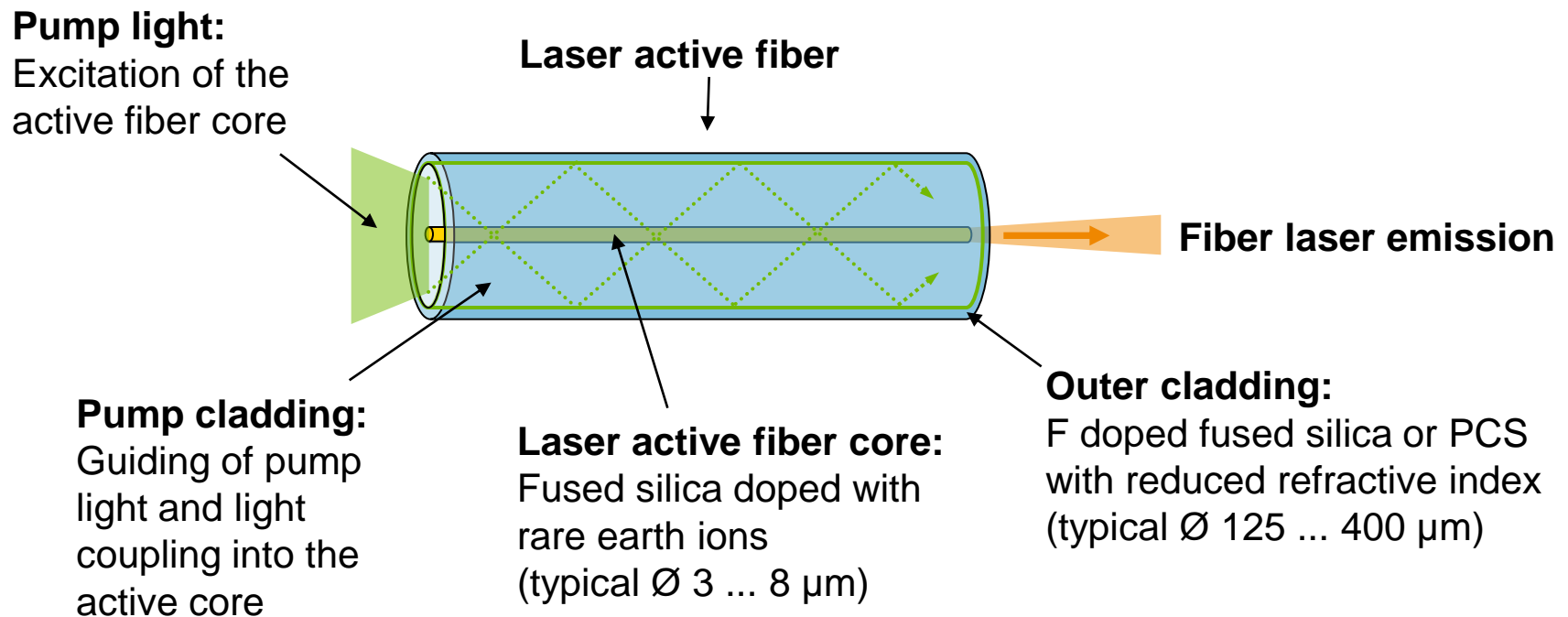

Production techniques of SSL gain media

Production of laser crystals

Czochralski technique

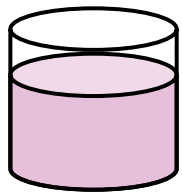

Melting of raw materials

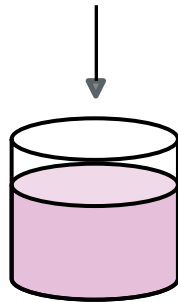

Insertion of seed crystal

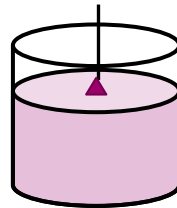

Start of crystal growth

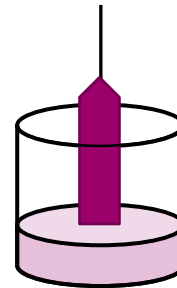

Pulling of crystal



- Low pulling speed 0.1 ... 3 mm/h. Growth time: few days up to 4 weeks
- Typical boule size: $\varnothing \sim 80$ mm, $l \sim 250$ mm
- Other manufacturing techniques possible, but usually poor crystal quality.

Production steps of a double clad fiber laser preform by MCVD

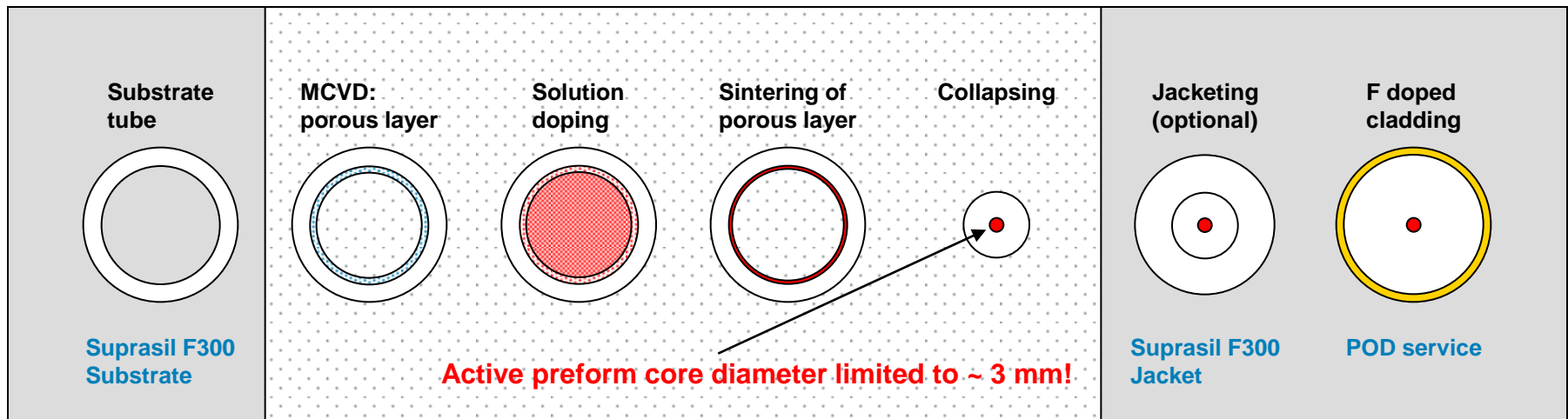

Drawback: Only small core diameters are possible!

Fabrication of Yb-doped bulk silica at Heraeus

Doping of a suspension of SiO_2 -particles with rare earth ions and co-dopants (e.g., Yb, Al, ...)

Dehydration and Granulation
⇒ Yb doped granulate

Sintering to a Yb-doped fused bulk silica



A. Langner et al., Proc. SPIE 6873 (2008)

Performance of the Yb-doped bulk silica

- **High Yb-doping levels possible:**
up to 0.25 mol % Yb_2O_3 and above
- **Current rod geometry:**
 \varnothing 15 mm, length up to 150 mm
- **High purity of Yb-doped synthetic fused silica**
- **Good material and doping level homogeneity**
- **Low defect and bubble density**
- **Low fiber base attenuation at 1200 nm below 0.1 dB/m:**
typical value: below 0.07 dB/m
actual best value: 0.012 dB/m (similar to MCVD)
- **Well suited for high power fiber laser applications**



Laser performance of the Yb-doped bulk silica

- Multimode double cladding fiber
($\varnothing_{\text{fiber}}$ 1000 μm , $\varnothing_{\text{core}}$ 45 μm)
- Wall plug efficiency > 25 %
- 5 weeks w/o failure
- **Maximum extracted laser power**
1.925 kW

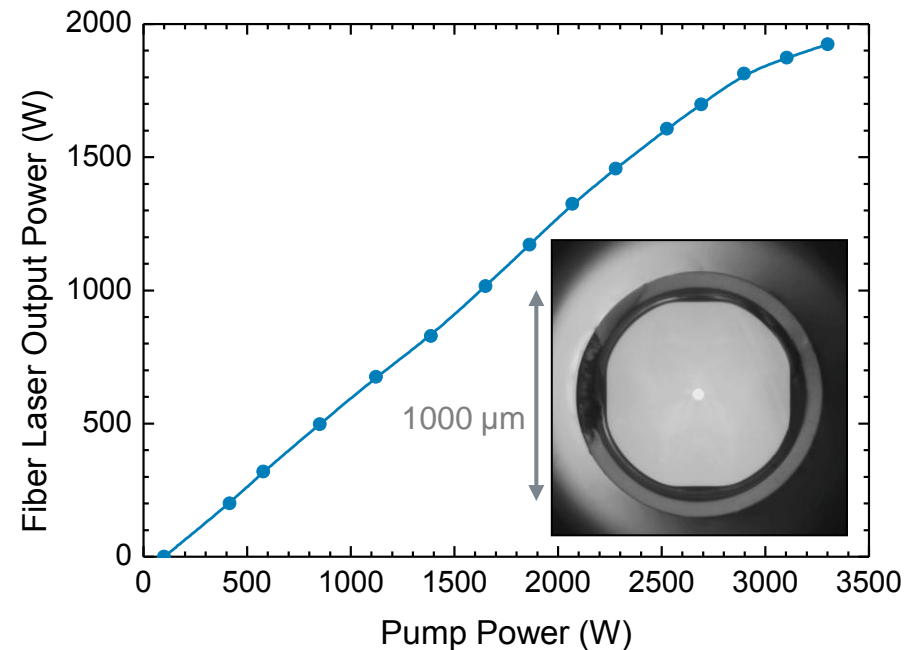

Partners:  laserline

HIGHYAG
Lasertechnologie

 ipht jena
INSTITUT für
PHOTONISCHE
TECHNOLOGIEN

Heraeus

Laser market and consequences of China's export control

Typical laser applications, revenues and forecast

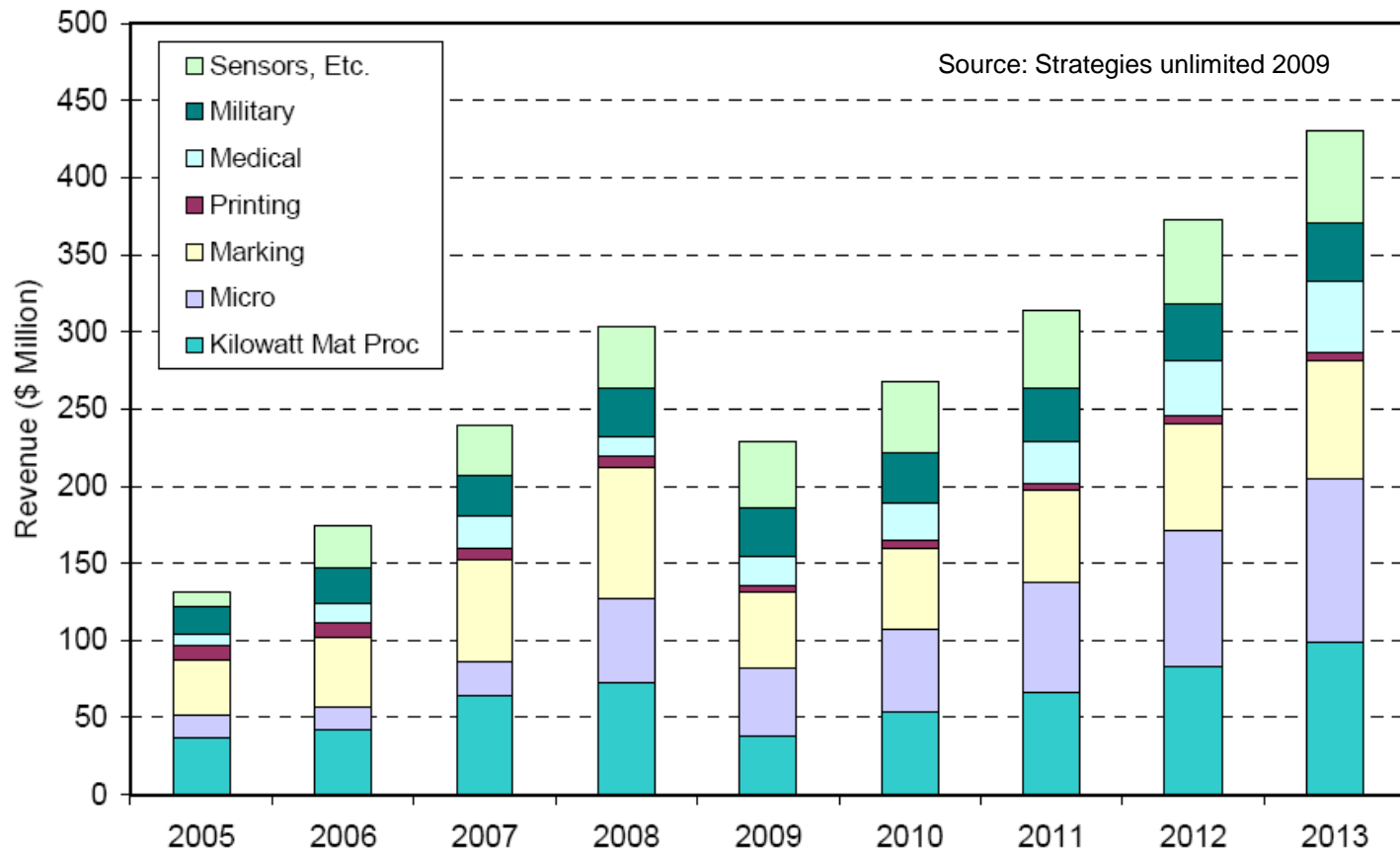

Laser revenues 2005 – 2008 and forecast

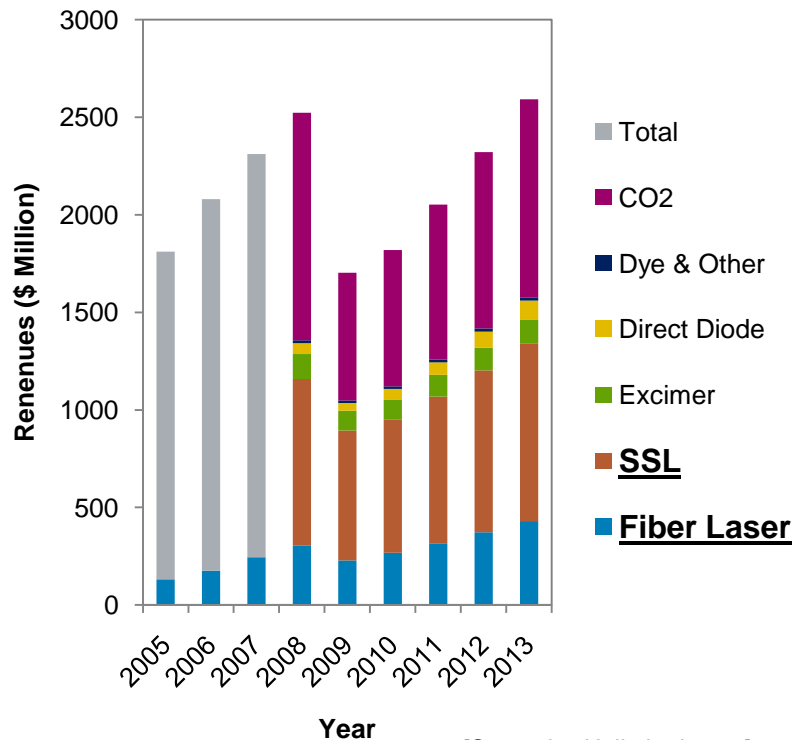

[Strategies Unlimited 2009]

- Market share of fiber laser still grows
- Market share of solid-state lasers (LPSSL, DPSSL, disk, slab) and fiber together ~ 50 %
- Revenue for SSL and fiber 2008: ~1200 million \$
- Raw material price is only a minor fraction of the laser system price

Availability of the rare earth elements

- **China controls 97 % of the world market**
(e.g. world production 2009: 124.000 t; China 120.000 t REO*)
[* Data from Mineral Commodity Summaries 2010]
- **China reduced the export of REO in 2010 significantly**
(reduction 72 % in 2010)
- **Economic consequences:**
 - Price increase of raw materials (up to 124 %)
 - Desired purity partly not available
 - No second source supplier available

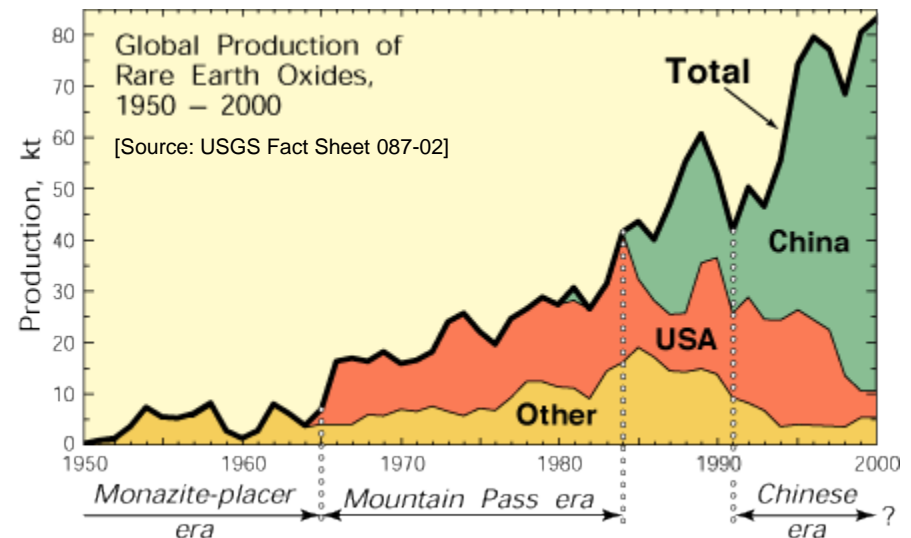

Demand of RE elements for laser gain media

- RE World market and demand for lasers is hard to estimate
- World market presumably less than a few hundred kg/yr
- Low demand compared to other applications such as magnets, batteries, catalysts (several thousand t/yr)
- RE elements are not replaceable for SSL
- Availability of desired purities might be an issue

Summary

- **RE elements are very important and not replaceable for lasers**
(LPSSL, DPSSL, disk laser, slab laser, fiber laser)
- **Most important RE elements:**
Y, Nd, Yb, Er, Ho, Tm, Ce, La,...
- **RE demand for lasers is low compared to other applications**
(e.g., magnets, batteries, catalysts)
- **Price increase of RE elements presumably not critical**
(raw material price is only a minor fraction of the laser system price)
- **High purity important for high laser gain**
⇒ **availability of desired purity might be problematic!**

Thank you for your attention!

[Image source: IPHT Jena]